

MITEL

Live Business Gateway

Telephony enabling Microsoft Office Communications Server 2007 R2 and Microsoft Office Communicator 2007 R2 through the Mitel 3300 IP Communications Platform (ICP).

The Mitel® Live Business Gateway allows the Microsoft® Office Communications Server 2007 R2 to communicate with a Mitel 3300 IP Communications Platform (ICP). The Live Business Gateway enables a user to place and receive calls from the Microsoft® Office Communicator 2007 R2 via a Mitel IP desktop phone. It also provides Communicator 2007 R2 and the Microsoft® Office system with the telephony status of enterprise users. The combination of Office Communications Server 2007 R2 and the Live Business Gateway enhances information worker productivity and greatly improves business process efficiencies by combining a wide range of collaboration tools with Mitel's trusted IP telephony solution.

Voice Integration

The Live Business Gateway provides voice integration between the 3300 ICP and Office Communications Server 2007 R2. Communicator 2007 R2 users are able to call via a Mitel IP desktop phone to any other internal or external telephone number. Live Business Gateway continues to provide voice integration to the 3300 ICP for Microsoft® Office Live Communications Server 2005 with Office Communicator 2005, and Office Communications Server 2007 with Communicator 2007.

Presence and Availability

Communicator 2007 R2 users are able to get a visual indication on the status of other users on the network, including a user's telephone status.

If a colleague or team member is busy on a call, the contact can be "tagged" so that when the user becomes free, a pop-up notification is provided to alert that this contact is now available.

Office Communications Server 2007 R2 Enhancements

Live Business Gateway Release 3.1 users are able to take advantage of many of the non-telephony feature enhancements available with Communicator 2007 R2 and Office Communications Server 2007 R2. These enhancements can be found on the Microsoft website.



Integration with Microsoft Outlook and the Microsoft Office System

Incoming calls to the Communicator 2007 R2 user that are not answered will be flagged as a missed call in the user's Microsoft® Outlook® inbox. In addition, a conversation folder within Outlook tracks all voice and IM conversations. A user's telephony presence can be seen from within Outlook or the Microsoft Office system. Calls can be established directly from within these applications through the click of a mouse. Out of office messages and calendar information can be synchronized with Communicator 2007 R2, enabling other users to get detailed information about a particular user's availability and whereabouts.

Flexible Deployment Options

Live Business Gateway is supported on either a Microsoft® Windows® operating system or Mitel Standard Linux¹. Mitel Standard Linux is a free of charge Linux®-based operating system that is becoming the operating system of choice for Mitel applications. Live Business Gateway is supported on a wide range of commercially available dual processor servers.

All licenses are controlled and managed via the Mitel Applications Management Center (AMC), simplifying installation procedures and providing a cost-effective method to add additional licenses.

Features

Live Business Gateway provides telephony enablement to Office Communications Server 2007 R2. Live Business Gateway integrates the Office Communications Server 2007 R2 with the 3300 ICP to provide access to key business resources in the moment they are needed, resulting in faster decision making and issue resolution.

- Missed calls are flagged to a user's Outlook inbox
- A conversation history is kept within a user's Outlook inbox
- Add video to a voice call at the click of a mouse
- Allows a user to place and receive calls from Communicator 2007 R2 and the Office system via a Mitel desktop phone

- Provides telephony presence of enterprise users to Communicator 2007 R2, Office Communications Server 2007 R2, and the Office system products
- Supports dual core servers (processors that incorporate two processors in a single chip)

Benefits

Teamwork today demands collaboration with more people in more organizations than ever before, regardless of geographic location. With Live Business Gateway, end users have the unprecedented ability to leverage voice, video, and data to locate and connect people, regardless of device or medium, and without leaving the current application.

Key Benefits

- Integrates Mitel's trusted voice solution with Office Communications Server 2007 R2 and Communicator 2007 R2
- Provides the user with a wide range of familiar Mitel IP phones
- The voice solution is not dependant on Office Communications Server 2007 R2, Communicator 2007 R2, or the PC
- Standards-based connectivity to Office Communications Server 2007 R2 via a single platform design
- Enables users to bring other media types into a voice call from an Microsoft Office application without creating separate communication sessions
- Provides end to-end voice network security for all calls between Mitel IP endpoints
- Integrates with existing voice equipment—avoids costly rip and replace
- Communicator 2007 R2 instant messaging and presence features are available to the user
- A wide range of telephony features are supported
- Office Communications Server 2007 R2, Office Communications Server 2007 and Live Communications Server 2005 are supported

¹ Linux® is the registered trademark of Linus Torvalds in the U.S. and other countries.

Mitel Live Business Gateway Call Flow Diagram

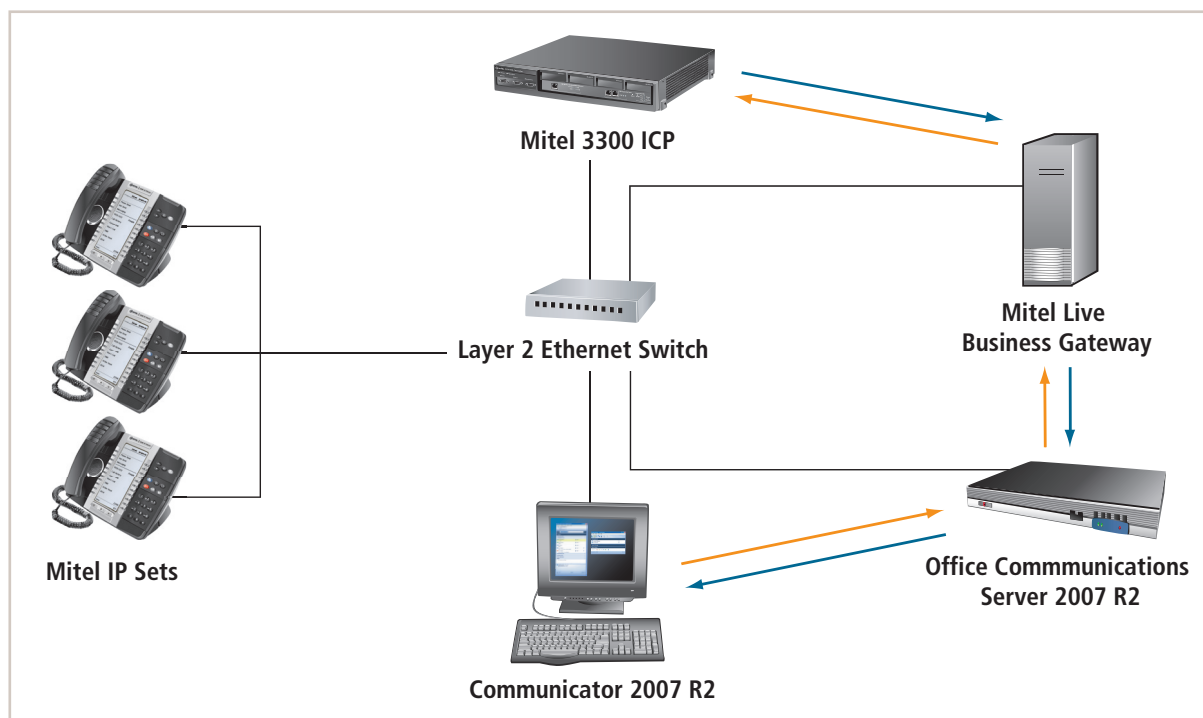

Hardware (Server)

Item	Requirement
CPU	1 GHz processor (minimum)
RAM	512 Mb (minimum)
Hard Drive	10 GB (minimum)
Operating Systems	(Microsoft® Windows®) Microsoft® Windows Server 2003 edition R2 (service pack 2) ² Microsoft Windows Server 2000 edition (service pack 4)
Operating Systems (Linux)	Mitel Standard Linux 8.5
Desktop Phone	Compatible Mitel phone and associated license ³

Software

Live Business Gateway software Release 3.1.0.18

General

Maximum number of users per server 2,500 at 10,000 CPH

Maximum number of users per APC 100 at 1,500 CPH

Maximum number of 3300 ICPs connected to a single server 10

Maximum number of 3300 ICPs connected to the APC 1

Supported languages English

3300 ICP and Mitel Communications Director (MCD) software 3300 ICP Release 9.0 UR2 and MCD 4.0 SP1 software

Mitel SX-200 IP Communications Platform (ICP) software Not supported

Mitel 5000 Communications Platform (CP) software Not Supported

² See the Live Business Gateway Release 3.1 Engineering guidelines for more information.

³ For a full list of compatible phones, see the Live Business Gateway Release 3.1 Engineering Guidelines for more information.



Global Headquarters	U.S.	EMEA	CALA	Asia Pacific
Tel: +1(613) 592-2122 Fax: +1(613) 592-4784	Tel: +1(480) 961-9000 Fax: +1(480) 961-1370	Tel: +44(0)1291-430000 Fax: +44(0)1291-430400	Tel: +1(613) 592-2122 Fax: +1(613) 592-7825	Tel: +852 2508 9780 Fax: +852 2508 9232

www.mitel.com

For more information on our worldwide office locations, visit our website at www.mitel.com/offices

THIS DOCUMENT IS PROVIDED TO YOU FOR INFORMATIONAL PURPOSES ONLY. The information furnished in this document, believed by Mitel to be accurate as of the date of its publication, is subject to change without notice. Mitel assumes no responsibility for any errors or omissions in this document and shall have no obligation to you as a result of having made this document available to you or based upon the information it contains.

M MITEL (design) is a registered trademark of Mitel Networks Corporation. All other products and services are the registered trademarks of their respective holders.

© Copyright 2009, Mitel Networks Corporation. All Rights Reserved.

GD 276_5008 PN 51010028RE-EN

